



Building a Better World
for All of Us®

INVITATION TO BID

TO: Bidders
FROM: Dave Blommel. PE
DATE: April 26, 2017
RE: Freeport, Minnesota
2017 Sanitary Sewer Improvements
SEH No. FREEP D08 52.00

Enclosed find the specification and plans for this project. Quotes are due:

Date: **May 8, 2017**
Day: **Monday**
Time: **2:00 p.m.**
Email: dblommel@sehinc.com
Location: **SEH**
1200 25th Avenue South
PO Box 1717
St. Cloud, MN 56302-1717

Emailed quotes are encouraged. Paper quotes can be dropped off at Freeport City Hall prior to the time listed above.

No Bid Bond is required.

Performance and Payment Bonds are not required.

Certificates of Insurance will be required.

Project Completion:

- Site is available immediately.
- The Final Completion of the project is June 1, 2017.

Project notes:

- Bypass pumping (as needed) is incidental.
- Bituminous Pavement:
 - Wear course used on School paving will be allowed for both lifts.
 - Second lift of pavement may be placed immediately after the first.
- Connect to existing MH includes enlarging the hole in the structure and installation of a sealant or boot to prevent groundwater from entering.

dwb/mrb

Enclosures

p:\fj\freep\common\general numbers\d08 2016 school gymnasium\5-final-dsgn\52-specs-proj-man\m bidders invite 042617.docx

The Bid is to be submitted on photocopies of this Bid Form and the attachments provided.

DOCUMENT 00 41 00

BID FORM

Total Amount of Bid \$ _____

Contractor's Name _____

Telephone _____

PROJECT IDENTIFICATION: 2017 Sanitary Sewer Improvements
Freeport, MN
SEH No. FREEP G08

BIDS TO BE OPENED: Monday, May 8, 2017 @ 2:00 p.m.

TABLE OF ARTICLES

	Page
Article 1 – Bid Recipient	1
Article 2 – Bidder's Acknowledgements	1
Article 3 – Bidder's Representations	2
Article 4 – Bidder's Certification.....	2
Article 5 – Basis of Bid.....	3
Article 6 – Time of Completion	3
Article 7 – Bid Submittal	3

ARTICLE 1 – BID RECIPIENT

- 1.01 This Bid is submitted to: **Honorable Mayor and City Council**
c/o Dave Blommel, PE
SEH
PO Box 1717
St Cloud, MN 56302-1717
dblommel@sehinc.com
- 1.02 The undersigned Bidder proposes and agrees, if this Bid is accepted, to enter into an Agreement with Owner in the form included in the Bidding Documents to perform all Work as specified or indicated in the Bidding Documents for the prices and within the times indicated in this Bid and in accordance with the other terms and conditions of the Bidding Documents.

ARTICLE 2 – BIDDER'S ACKNOWLEDGEMENTS

- 2.01 Bidder accepts all of the terms and conditions of the Instructions to Bidders, including without limitation those dealing with the disposition of Bid security. The Bid will remain subject to acceptance for 60 days after the day of Bid opening, or for such longer period of time that Bidder may agree to in writing upon request of Owner.

ARTICLE 3 – BIDDER’S REPRESENTATIONS

3.01 In submitting this Bid, Bidder represents that:

- A. Bidder has examined and carefully studied the Bidding Documents, and any data and reference items identified in the Bidding Documents, and hereby acknowledges receipt of the following Addenda:

Addendum No.	Addendum Date
_____	_____
_____	_____
_____	_____

- B. Bidder has visited the Site, conducted a thorough, alert visual examination of the Site and adjacent areas, and become familiar with and satisfied itself as to the general, local, and Site conditions that may affect cost, progress, and performance of the Work.
- C. Bidder is familiar with and is satisfied as to all Laws and Regulations that may affect cost, progress and performance of the Work.
- D. Bidder has considered the information known to Bidder itself; information commonly known to contractors doing business in the locality of the Site; information and observations obtained from visits to the Site; the Bidding Documents; and any Site-related reports and drawings identified in the Bidding Documents, with respect to the effect of such information, observations, and documents on (1) the cost, progress, and performance of the Work; (2) the means, methods, techniques, sequences, and procedures of construction to be employed by Bidder, and (3) Bidder’s safety precautions and programs.
- E. Bidder agrees, based on the information and observations referred to in the preceding paragraph, that no further examinations, investigations, explorations, tests, studies, or data are necessary for the determination of this Bid for performance of the Work at the price(s) bid and within the times and in accordance with the other terms and conditions of the Bidding Documents.
- F. Bidder is aware of the general nature of work to be performed by Owner and others at the Site that relates to the Work as indicated in the Bidding Documents.
- G. Bidder has given Engineer written notice of all conflicts, errors, ambiguities, or discrepancies that Bidder has discovered in the Bidding Documents, and confirms that the written resolution thereof by Engineer is acceptable to Bidder.
- H. The Bidding Documents are generally sufficient to indicate and convey understanding of all terms and conditions for the performance and furnishing of the Work.

ARTICLE 4 – BIDDER’S CERTIFICATION

4.01 Bidder certifies that:

- A. This Bid is genuine and not made in the interest of or on behalf of any undisclosed individual or entity and is not submitted in conformity with any collusive agreement or rules of any group, association, organization, or corporation;
- B. Bidder has not directly or indirectly induced or solicited any other Bidder to submit a false or sham Bid;
- C. Bidder has not solicited or induced any individual or entity to refrain from bidding; and
- D. Bidder has not engaged in corrupt, fraudulent, collusive, or coercive practices in competing for the Contract. For the purposes of this Paragraph 4.01.D:
 - 1. “corrupt practice” means the offering, giving, receiving, or soliciting of anything of value likely to influence the action of a public official in the bidding process;
 - 2. “fraudulent practice” means an intentional misrepresentation of facts made (a) to influence the bidding process to the detriment of Owner, (b) to establish bid prices at artificial non-competitive levels, or (c) to deprive Owner of the benefits of free and open competition;

3. "collusive practice" means a scheme or arrangement between two or more Bidders, with or without the knowledge of Owner, a purpose of which is to establish bid prices at artificial, non-competitive levels; and
4. "coercive practice" means harming or threatening to harm, directly or indirectly, persons or their property to influence their participation in the bidding process or affect the execution of the Contract.

ARTICLE 5 – BASIS OF BID

5.01 Bidder will complete the Work in accordance with the Contract Documents for the following unit price(s):

ITEM NO.	DESCRIPTION	UNIT	ESTIMATED QUANTITY	BID UNIT PRICE	BID PRICE
1	MOBILIZATION	LUMP SUM	1.00		
2	REMOVE BITUMINOUS PAVEMENT	SQ YD	125.00		
3	SAWCUT BITUMINOUS PAVEMENT	LIN FT	77.00		
4	12" PVC SDR 35 SANITARY SEWER	LIN FT	74.00		
5	CONNECT TO EXISTING MH	EACH	2.00		
6	RECONSTRUCT INVERT IN UPSTREAM MH	LUMP SUM	1.00		
7	CLASS 5 AGGREGATE BASE (12" THICKNESS)	CU YD	40.00		
8	4" BITUMINOUS WEAR COURSE	TON	28.00		
TOTAL BID					

ARTICLE 6 – TIME OF COMPLETION

6.01 Bidder agrees that the Work will be substantially complete and completed and ready for final payment in accordance with dates identified in the quote memorandum.

ARTICLE 7 – BID SUBMITTAL

7.01 This Bid submitted by:

If Bidder is:

An Individual

Name (typed or printed): _____

By: _____ (SEAL)
(Individual's signature)

Doing business as: _____

A Partnership

Partnership Name: _____ (SEAL)

By: _____
(Signature of general partner - attach evidence of authority to sign)

Name (typed or printed): _____

A Joint Venture

Name of Joint Venturer: _____

First Joint Venturer Name: _____ (SEAL)

By: _____
(Signature of first joint venture partner - attach evidence of authority to sign)

Name (typed or printed): _____

Title: _____

Second Joint Venturer Name: _____ (SEAL)

By: _____
(Signature - attach evidence of authority to sign)

Name (typed or printed): _____

Title: _____

(Each joint venturer must sign. The manner of signing for each individual, partnership, and corporation that is a party to the joint venture should be in the manner indicated above.)

A Corporation

Corporation Name: _____ (SEAL)

State of Incorporation: _____

Type (General Business, Professional, Service, Limited Liability): _____

By: _____
(Signature - attach evidence of authority to sign)

Name (typed or printed): _____

Title: _____
(CORPORATE SEAL)

Attest: _____
(Signature of Corporate Secretary)

Date of Qualification to do business in _____ is ____/____/____.
(State Where Project is Located)

7.02 Contact Information

Bidder's Business Address: _____

Phone: _____ Facsimile: _____ E-mail: _____

Submitted on _____, 20____.

State Contractor License No. _____. (If applicable)



MH 1
 TC — 1228.68
 INV — 1221.43

74 LF 12" SDR 35 @ 0.23%

MH 2
 TC — 1228.28
 INV W— 1221.26
 INV S — 1220.93



FILE NO.
 FREEP G08

DATE:
 04/25/17

SANITARY SEWER LAYOUT

25 FREEPORT, MN

**EXHIBIT
 NO. 1**

MANHOLE 1 EXISTING

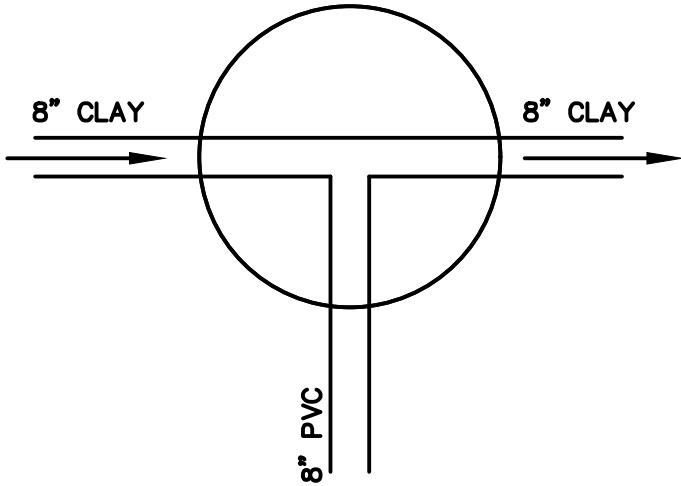

MANHOLE 1 PROPOSED

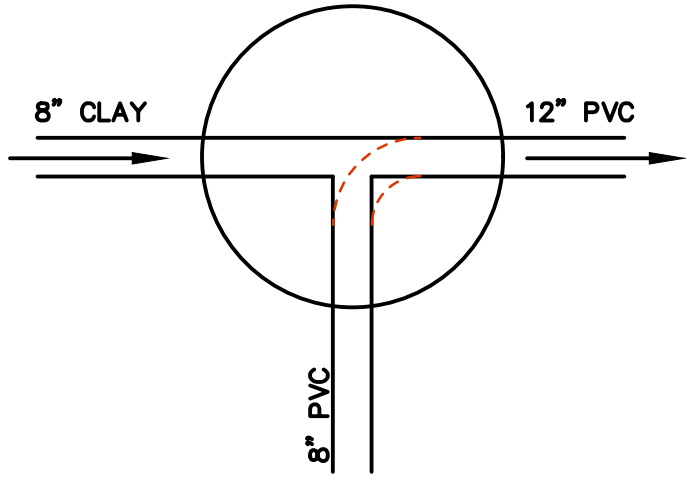

**WORK ON MH:
CONNECT TO EXISTING MH
RECONSTRUCT INVERT**

MANHOLE 2 EXISTING

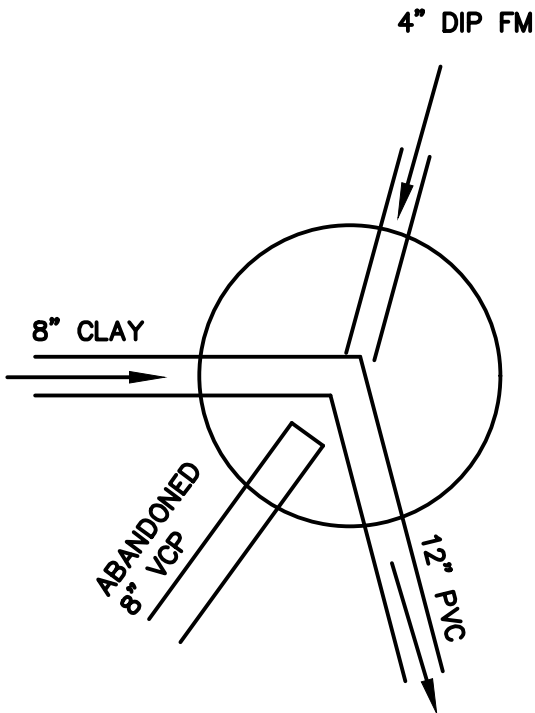

MANHOLE 2 PROPOSED

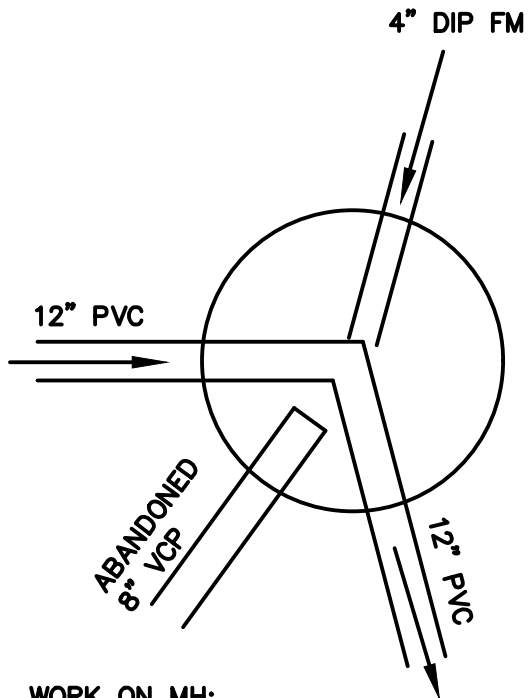

**WORK ON MH:
CONNECT TO EXISTING MH**



FILE NO.
FREEP G08

DATE:
04/25/17

MANHOLE CONFIGURATION

26 FREEPORT, MN

**EXHIBIT
NO. 2**

3. "collusive practice" means a scheme or arrangement between two or more Bidders, with or without the knowledge of Owner, a purpose of which is to establish bid prices at artificial, non-competitive levels; and
4. "coercive practice" means harming or threatening to harm, directly or indirectly, persons or their property to influence their participation in the bidding process or affect the execution of the Contract.

ARTICLE 5 – BASIS OF BID

5.01 Bidder will complete the Work in accordance with the Contract Documents for the following unit price(s):

ITEM NO.	DESCRIPTION	UNIT	ESTIMATED QUANTITY	BID UNIT PRICE	BID PRICE
1	MOBILIZATION	LUMP SUM	1.00	2800 ⁰⁰	2800 ⁰⁰
2	REMOVE BITUMINOUS PAVEMENT	SQ YD	125.00	2 ⁰⁰	250 ⁰⁰
3	SAWCUT BITUMINOUS PAVEMENT	LIN FT	77.00	3 ²⁵	250 ²⁵
4	12" PVC SDR 35 SANITARY SEWER	LIN FT	74.00	90 ⁰⁰	6660 ⁰⁰
5	CONNECT TO EXISTING MH	EACH	2.00	1000 ⁰⁰	2000 ⁰⁰
6	RECONSTRUCT INVERT IN UPSTREAM MH	LUMP SUM	1.00	275 ⁰⁰	275 ⁰⁰
7	CLASS 5 AGGREGATE BASE (12" THICKNESS)	CU YD	40.00	25 ⁰⁰	1000 ⁰⁰
8	4" BITUMINOUS WEAR COURSE	TON	28.00	105 ⁰⁰	2940 ⁰⁰
TOTAL BID				16,175 ²⁵	

ARTICLE 6 – TIME OF COMPLETION

6.01 Bidder agrees that the Work will be substantially complete and completed and ready for final payment in accordance with dates identified in the quote memorandum.

ARTICLE 7 – BID SUBMITTAL

7.01 This Bid submitted by:

If Bidder is:

An Individual

Name (typed or printed): Chris Kotzer

By:  (SEAL)
 (Individual's signature)

Doing business as: Kotzer Excavating Inc.

Dymoke Law Office, P.A.

300 Riverside Avenue NW

Melrose, Minnesota 56352

Telephone (320) 256-4205

Fax (320) 256-7201

May 23, 2017

Adrianna Hennen
City of Freeport
125 Main Street East
Freeport, MN 56331

BY ELECTRONIC MAIL

Re: Monthly Legal Report

Dear Ms. Hennen:

During the period from April 18, 2017 through May 23, 2017, we have given significant attention to the following projects on behalf of the City of Freeport:

- Rural Service District
Reviewed state statute and city ordinance governing Rural Service Districts and identified existing Rural Service Districts in Freeport. Prepared and forwarded summary of the effect of Rural Service District ordinance on property tax collections to City Clerk.
- City Contracts
Reviewed notice from State Auditor stating that certain contracts with City Officials did not comply with state requirements. Reviewed state statutes governing contracts with City Officials and forwarded recommendations for bringing contracts into compliance to City Clerk.
- Zoning Regulations
Reviewed request to construct garage with second floor apartment. Reviewed zoning regulations, prepared and forwarded opinion to City Clerk that Freeport's zoning regulations do not permit garages with a second floor apartment in R-1 District.

Respectfully submitted,
Dymoke Law Office, P.A.

by Scott E. Dymoke

Memo

From: Adrianna Hennen, Clerk-Treasurer

To: Freeport City Council

Date: 5/25/17

Re: Public Nuisances

Chris Welle: Notice was sent to him to make some improvements to his home – Siding falling off, etc. Gave a deadline of June 23rd.

Fast Lane: Brian has cleaned up his tires and removed a few vehicles. I informed him that we appreciated the effort, but continued removal of vehicles is required.

Hoeschen Auto: Notice was sent for them to remove the junk vehicles located behind the building and in the alley way. Need to be removed by June 23rd.

Jim Buetz: Sent notice which reminded him of how much wood is allowed on a property and that he was currently over the limit. He returned the notice with a note “work in progress” on it.

Marven Finken: Notified me that they were going to be painting the house in the next couple of weeks.

Tom Gruber: Working on getting in contact with him again and seeing where he is with home improvement plans.

Memo

From: Adrianna Hennen, Clerk-Treasurer

To: Freeport City Council

Date: 5/25/17

Re: Easement/Lift Station Behind Sacred Heart School

The Parish has recently been questioning the easement located behind school. They don't understand why a cul-du-sac was developed onto the school property, which is now allowing people to drive onto the property and park in the area. The Parish is concerned there might be liability issues if anything were to happen in that area. They are trying to be cautious in light of the recent vandalism to the gymnasium.

Currently Dave has set it up with Kotzer to not put the tar back in where they are removing it to change out the sewer line. I would like to decide if they feel we should pay to have that tar put back in or not.

Also, the Parish has asked that we pay to put in a gate at the end of the road so that people cannot trespass onto the Parish property. Loren would have a key to the gate so he has access to the lift station.

I have invited Jim and Fr. Dan to the meeting to discuss this matter.

Attached is also a picture of the area for a visual.



Memo

From: Joan Wall, Deputy Treasurer

To: Freeport City Council

Date: May 23, 2017

Re: Water & Sewer Charges for Services Trends

When the 2017 1st quarter financials were presented at the April 25 Council meeting, it was noted that the Charges for Services revenue for the Water Fund appeared low in comparison to the budget. I compared this year's revenue with the trends over the last several years to see if this year's revenue was low in comparison to previous years.

The spreadsheets appear on the next two pages for the Water Fund and the Sewer Fund.

- The "Bills Paid" column shows the dollar amount the City received to pay utility bills for each month.
- In Accounting, we utilize a 13th period named "Audit" to record year-end adjustments. In this case, these year-end adjustments are to record December usage (not billed until January) in the proper year. These year-end adjustments are then reversed in January of the next year.
- Because utility rates have changed over the years, we can't get an accurate comparison by looking at dollars alone. The "Percentage" columns were added because the percentage of revenue received in each month should be relatively similar from year to year, even if dollar amounts are not.
- The "%" column shows the percentage of the year's revenue received in each period.
- The "YTD %" column shows the percentage of the year's revenue received from January through April of each year.
- In the 2017 columns, the percentages are calculated using the annual budgeted revenue for the year since we don't have actual revenue received yet. This way, we can compare apples to apples across all years.
- **Bottom line: The percentage of revenue received so far in 2017 is similar to what we have received in previous years, especially 2015 and 2016. It looks like we are on track to meet our annual budget. We will keep watching this as the year progresses.**

City of Freeport
Water Fund (601) Charges for Services Trend

	2012			2013			2014			2015			2016			2017		
	Bills Paid	%	YTD %	Bills Paid	%	YTD %	Bills Paid	%	YTD %	Bills Paid	%	YTD %	Bills Paid	%	YTD %	Bills Paid	%	YTD %
January	(1,476)	-1.0%		(3,898)	-2.5%		9,700	6.0%		(6,316)	-3.9%		(7,837)	-5.0%		(8,973)	-7.9%	
February	11,888	7.7%		8,379	5.3%		11,613	7.2%		16,211	10.1%		17,948	11.4%		9,942	8.7%	
March	12,521	8.1%		18,096	11.5%		15,535	9.6%		14,260	8.9%		8,557	5.4%		13,310	11.6%	
April	12,739	8.2%	23.0%	11,368	7.2%	21.6%	9,626	6.0%	28.8%	8,396	5.2%	20.3%	14,075	8.9%	20.7%	7,583	6.6%	19.1%
May	12,499	8.1%		14,582	9.3%		14,753	9.2%		11,868	7.4%		8,544	5.4%			0.0%	
June	14,036	9.1%		10,241	6.5%		13,738	8.5%		12,070	7.5%		19,923	12.6%			0.0%	
July	10,350	6.7%		15,713	10.0%		14,252	8.8%		17,582	10.9%		13,939	8.8%			0.0%	
August	15,802	10.2%		14,766	9.4%		13,322	8.3%		15,146	9.4%		14,067	8.9%			0.0%	
September	12,491	8.1%		16,135	10.3%		14,166	8.8%		14,160	8.8%		11,798	7.5%			0.0%	
October	13,450	8.7%		12,045	7.7%		14,537	9.0%		11,121	6.9%		15,008	9.5%			0.0%	
November	14,299	9.2%		12,295	7.8%		10,694	6.6%		15,530	9.7%		10,099	6.4%			0.0%	
December	11,678	7.5%		14,398	9.2%		2,350	1.5%		11,067	6.9%		15,849	10.0%			0.0%	
Audit	14,668	9.5%		13,092	8.3%		16,914	10.5%		19,581	12.2%		16,057	10.2%			0.0%	
	<u>154,945</u>	<u>100.0%</u>		<u>157,213</u>	<u>100.0%</u>		<u>161,200</u>	<u>100.0%</u>		<u>160,675</u>	<u>100.0%</u>		<u>158,027</u>	<u>100.0%</u>		<u>21,861</u>	<u>19.1%</u>	

2017 Annual Budget

114,280

City of Freeport
Sewer Fund (602) Charges for Services Trend

	2012			2013			2014			2015			2016			2017		
	Bills Paid	%	YTD %	Bills Paid	%	YTD %	Bills Paid	%	YTD %	Bills Paid	%	YTD %	Bills Paid	%	YTD %	Bills Paid	%	YTD %
January	(2,934)	-3.8%		(2,610)	-3.3%		4,617	5.8%		(3,458)	-4.4%		(4,266)	-4.9%		(8,514)	-6.3%	
February	4,770	6.2%		4,543	5.8%		6,003	7.6%		7,800	9.8%		8,710	9.9%		11,542	8.5%	
March	7,055	9.1%		8,926	11.4%		7,532	9.5%		6,919	8.7%		4,416	5.0%		14,150	10.4%	
April	6,980	9.0%	20.5%	5,714	7.3%	21.2%	4,815	6.1%	28.9%	4,345	5.5%	19.7%	6,807	7.7%	17.8%	9,020	6.6%	19.3%
May	6,281	8.1%		7,375	9.4%		7,268	9.2%		5,964	7.5%		4,233	4.8%			0.0%	
June	7,045	9.1%		4,903	6.3%		6,849	8.6%		5,707	7.2%		9,687	11.0%			0.0%	
July	5,483	7.1%		7,822	10.0%		6,780	8.5%		8,772	11.1%		7,446	8.5%			0.0%	
August	8,219	10.6%		7,271	9.3%		6,290	7.9%		7,405	9.3%		7,329	8.3%			0.0%	
September	6,212	8.0%		7,892	10.1%		6,967	8.8%		6,701	8.5%		6,242	7.1%			0.0%	
October	7,009	9.1%		5,971	7.6%		6,965	8.8%		5,628	7.1%		8,001	9.1%			0.0%	
November	6,856	8.9%		6,268	8.0%		5,337	6.7%		7,604	9.6%		5,517	6.3%			0.0%	
December	6,120	7.9%		7,052	9.0%		1,297	1.6%		5,609	7.1%		8,496	9.7%			0.0%	
Audit	8,160	10.6%		7,033	9.0%		8,712	11.0%		10,249	12.9%		15,293	17.4%			0.0%	
	<u>77,256</u>	<u>100.0%</u>		<u>78,160</u>	<u>100.0%</u>		<u>79,431</u>	<u>100.0%</u>		<u>79,244</u>	<u>100.0%</u>		<u>87,911</u>	<u>100.0%</u>		<u>26,198</u>	<u>19.3%</u>	

2017 Annual Budget

135,800

Memo

From: Adrianna Hennen, Clerk-Treasurer

To: Freeport City Council

Date: 5/25/17

Re: Rural Service District

Following this memo you will find a copy of the City Code that discusses an established Rural Service District. We were unaware we had this district until Stearns County started questioning some of the parcels that are still included in the district and Dymoke looked into it.

Included are also maps of each of the parcels that are a part of the district. When the district was originally established, it gave the specified parcels a 50% tax break. It is now up to the council how you would like to continue with the district. Alter, add, remove?

There is also a sheet that shows the tax breakdowns for the parcels that are included in the Rural Service District.

Section 505 – Urban and Rural Service Districts

505.01 Policy	1
505.03 Districts	1
Subd.1 Established.....	1
Subd.2 Rural Service District	1
Subd.3 Urban Service District	1
505.05 Tax Capacity District	2
505.07 Amendment.....	2
505.09 Application.....	2

505.01 Policy

The city council has reviewed the use of land in the city and has reviewed the current cost of government services offered to the residents and landowners of the city, the current source of funds for those services, and the current approximate relative benefits to urban and rural land in the city from tax support municipal services. The city council has concluded that it would be desirable to establish an urban service district and a rural service district for the purposes of all municipal property taxes except those levied for the payment of debt service on bonds and judgments pursuant to Minnesota Statutes, Section 272.67.

505.03 Districts

Subd.1 Established

An urban service district and a rural service district exist in the city for the purpose of municipal property taxes except those levied for payment of debt bonds and judgments and interest thereon.

Subd.2 Rural Service District

The following parcels of land in the city comprise the rural service district:

1. Parcel number 54-32021-00
2. Parcel number 54-32028-00
3. Parcel number 54-32085-00
4. Parcel number 54-32051-00

The City Council finds that the land in the rural service district is un-platted and rural in character and none of it is developed for commercial, industrial, or urban residential purposes. The council also finds that all parcels are greater than the 18 acre minimum size established by the council and are utilized as active agricultural farming operations.

Subd.3 Urban Service District

Land in the city other than that included in rural service district is in the urban service district.

505.05 Tax Capacity District

The parcels of land in the rural service district receive approximately 50% of the benefits resulting from tax supported municipal service as compared to parcels of land of like value in the urban service district. Therefore, the tax capacity rate to be levied upon the rural service district lands will be 50% of urban district mill rate.

505.07 Amendment

This Section may be amended to change the above benefit ratio or to add or remove lands from the rural service district. An amendment is not required to remove lands which are to be developed for commercial, industrial or residential uses in accordance with Minnesota Statutes, Section 272.67, subd.5.

505.09 Application

This Section applies to taxes payable in 1986 and subsequent years subject to amendment as provided by law.